

# Considerations in miniaturizing simplified agro-ecosystems for advanced life support

Tyler Volk

*Earth Systems Group, Biology Department, New York University, 34 Stuyvesant Street, New York, NY  
10003-7599, USA*

Received 26 January 1994; revised 12 February 1995; accepted 5 September 1995

---

## Abstract

Miniaturizing the Earth's biogeochemical cycles to support human life during future space missions is the goal of the NASA research and engineering program in advanced life support. Mission requirements to reduce mass, volume, and power have focused efforts on (1) a maximally simplified agro-ecosystem of humans, food crops, and microbes; and, (2) a design for optimized productivity of food crops with high light levels over long days, with hydroponics, with elevated carbon dioxide and other controlled environmental factors, as well as with genetic selection for desirable crop properties. Mathematical modeling contributes to the goals by establishing trade-offs, by analyzing the growth and development of experimental crops, and by pointing to the possibilities of directed phasic control using modified field crop models to increase the harvest index.

*Keywords:* CELSS; Mesocosm; Crop growth; Mathematical modeling; Space agriculture

---

## 1. Introduction

The greenhouse-scale of a mesocosm presents some exciting opportunities for research. Bigger than a test tube, smaller than the Earth or most natural ecosystems, and with more defined boundaries in terms of spatial limits and degree of control of entries and exits, the mesocosm reduces natural complexity through its act of encapsulation. A mesocosm, nevertheless, still contains complexity galore. Usually it includes many types of organisms on multiple trophic levels and their intricate coupling to the biochemistry of operating fluids and solid substrates.

One very different type of mesocosm being studied by a diverse range of researchers for a highly specific goal is the focus of the NASA program in advanced life support,

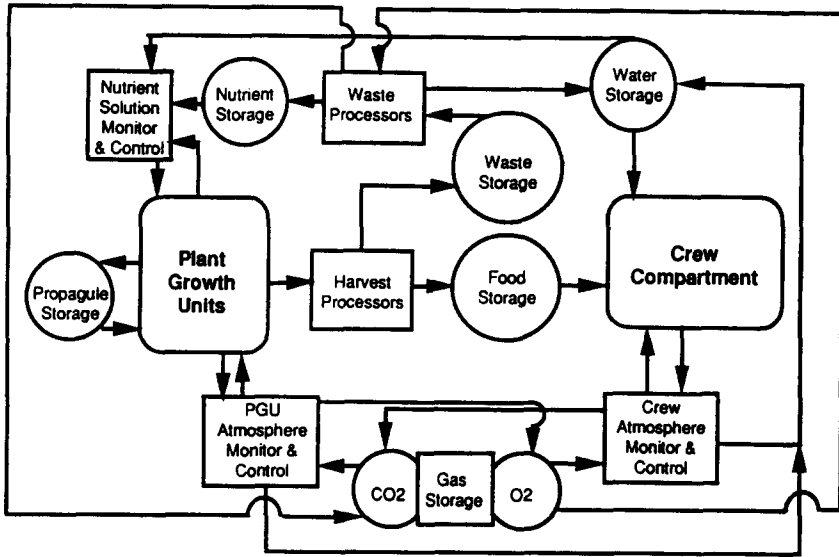

Fig. 1. Schematic of an advanced life-support system.

which for many years has gone by the acronym CELSS, for Controlled Ecological Life Support Systems. As defined by one of the founders of the program, Robert MacElroy of NASA's Ames Research Center:

"The CELSS program is a research effort that has the goal of providing the research and technology base required to develop a bioregenerative life support system for use in extraterrestrial environments. Such environments include orbiting space stations, the lunar surface, transits to the outer planets, and bases on Mars and the asteroids." (MacElroy et al., 1987)

Basically, a CELSS will be a mesocosm with a high degree of material closure. It will continually provide for its human occupants their water, oxygen, and food, as well as disposing of their material wastes. A schematic of such a system is shown in Fig. 1. To whatever extent biology will ultimately contribute to the various life support loops, it is already clear that such systems will indeed be a unique type of mesocosm. In MacElroy's words again:

"The CELSS concept is based on the natural processes of recycling that occur in the terrestrial environment. It is assumed that by artificially creating similar cycles of materials within small, closed systems, a usable ecosystem can be produced which is capable of supporting a crew. However, a CELSS is not directly analogous to the terrestrial ecosystem because its volume and the sizes of its materials reservoirs are minute, and the rates of material cycling are much faster. Such characteristics dictate that the system be highly engineered and controlled." (MacElroy et al., 1987)

A crucial word is "small". This translates into efficient use of mass, energy, and volume for all space systems. And, as will be elaborated here, the advanced life support program aims for smallness by simplifying and by miniaturizing. These goals have focused much initial research on the all-important component of crops.

## 2. Simplified CELSS

First and above all, a CELSS is human-centered. As in Biosphere 2 (Nelson et al., 1993) and the Russian Bios 3 facility (Gitelson and Okladnikov, 1994), in a CELSS the humans are the keystone species. And this species currently intends to direct as much of the products of photosynthesis towards itself as possible. Plants other than food crops are not planned for inclusion.

Using precious planting area to specifically grow crops to feed meat animals would also be inefficient because the animals respire and produce wastes during their growth. In another possible scenario, only the inedible parts of the human-aimed food crops would be fed to animals. This would add a substantial degree of complexity: the animals themselves, the animal habitats, and the means for slaughter and butchering. The advantages of limiting the biological animal component to the human species provide a nearly irresistible and perhaps necessary simplification, at least initially and for systems smaller than space hamlets.

The centrality of humans and their food crops means that the CELSS agro-ecosystem becomes virtually as simple as possible. It is nearly identical to that most elementary concept of ecology: a binary cycle between producer and consumer.

Usually, of course, the elementary cycle is shown as a 3-fold circuit around producer, consumer, and decomposer. With food crops as the producer component and humans as the consumer component (as generic herbivore), in a CELSS the decomposer is the subsystem called waste processing. This processing is necessary since most human wastes (except for the exhaled CO<sub>2</sub> and some portions of urine) are not utilizable by the plants directly but must be converted into mineral forms. In nature the final steps in waste processing that create the requisite dissolved mineral forms of elements come predominantly from bacteria and, to some degree, fungi and protozoa. Whether or not such organisms would be used in a CELSS is still a matter of debate and research and thus worth some further discussion here.

The waste processing subsystem would receive liquid and solid wastes from human metabolism, a variety of wash liquids, and food preparation scraps. An additional concern is the large amount of harvested biomass that is usually deemed inedible because of its cellulose, hemicellulose, and lignin contents. A potential role for microbes or fungi derives from the abilities of some types to attack the cellulose bonds and to initiate a series of biologically-mediated transformations of the plant wastes into the more potentially usable glucose (Westgate et al., 1992). The glucose could be used for fuel or for food, either directly or via another, edible fungi. However, these processes themselves have considerable losses and would require a non-trivial array of separately controlled environments specifically for the organisms involved in the waste processing.

Furthermore, the efficacy of using such so-called bioprocessing is sensitive to the harvest index, which is the edible fraction of the total plant biomass at harvest. As an example, wheat has a harvest index of about 45%. If the 55% of the wheat plant that is inedible is put into the stages of bioprocessing (with the current estimates for energy losses at each stage), the system could be designed with a planting area that is 13% less than what would be required without bioprocessing (Volk, 1993). The functional dependence between harvest index and savings is nonlinear: performing the same

calculation for potato, with an 80% harvest index, yields only a 3% saving in total planting area.

Whether or not such reductions in planting area are enough to drive the overall design to include a bioprocessing component will need more thought. The bioprocessing system might require more mass than would a purely physical-chemical waste processor. It would certainly add a level of biological complexity and the ensuing disadvantages and advantages for overall stability and control will have to be carefully considered.

One option is to eliminate life from the waste processing subsystem. This would mean that purely physical and chemical equipment would perform the major task: to convert all organic molecular species into forms usable by the plants at the next stage in the CELSS cycle.

It has sometimes been argued that only life – with its nearly four billion-year-old evolved experience in closing the system – can make all the transformations necessary for the many macro- and micro-nutrients that must be recycled. Biosphere 2, for example, cleanses its air from volatile organics by passing it through the soil (Nelson et al., 1993). The concept is that the populations of soil microbes can regulate their numbers based on the available volatiles (food for them). This frees the human designers from having to specify detailed physical solutions that might require complex dynamics in various unknown and transient situations. The Russian Bios 3 facility used both the plants and thermocatalytic filters for the air cleansing (Gitelson et al., 1989).

It must, however, be noted that a high degree of material closure in a CELSS is a goal that helps drive research but is not an absolute operational necessity. CELSS is intended to support space operations, which themselves will always require transport to and from Earth for the myriad arrays of scientific and technical equipment. Therefore, methods of food growth and waste recycling will quite likely be introduced primarily as cost-effective replacements against re-supply from Earth (the important psychological aspects of fresh vegetables and satisfying biophilia are not discussed here). For example, about 80% of the food carbon ingested by humans is recycled for free into a form usable by the plants in the exhaled breath (Volk and Rummel, 1987).

Furthermore, relatively simple and off-the-shelf technology such as microwave incinerators can oxidize organic wastes with only a trace of carbon remaining in the ash (Cory Finn, NASA Ames Research Center, pers. comm., 1994). About 90% of the dry mass from crops consists of the elements carbon, hydrogen, and oxygen (Bugbee and Salisbury, 1989). Thus, an incinerator (or more sophisticated wet or super-critical wet oxidation), if able to convert the carbon, hydrogen, and oxygen in organic wastes (with the stoichiometric additional oxygen, of course) into carbon dioxide and water, could accomplish 90% of the total potential mass recycling.

The siting of a CELSS will also play into the trade-off decisions about what and what proportions to recycle. The dearth of carbon and hydrogen on the moon (although oxygen in rocks is abundant, see Ming and Henninger, 1989) reinforces the need to recycle these major elements in a lunar CELSS. On Mars the situation literally gets blown wide open. With abundant carbon dioxide in its atmosphere (more than the Earth's) and with not insignificant amounts of water vapor and nitrogen that could be "harvested" by physical-chemical means, closure of a life support system on Mars is, again, only an ideal that must be weighed against the available external resource base.

For example, on Mars a CELSS might go beyond its initial simplified design that ignores non-food plants to eventually include "cellulose farms" for funneling a steady stream of fixed carbon compounds as feedstocks for plastics, fuels, paper, furniture, and building materials (Volk and Rummel, 1989).

Regardless of whether or not bacteria are an integral part of the waste treatment in the initial CELSS designs, the simplified system will somewhere contain a microbial component. Bacteria will inhabit wherever they can colonize – around plant roots and in the nutrient solution, in the mouths and guts of people, essentially in all nooks and crannies. Therefore, bacteria are indeed an irreducible third living component; although the humans might regard the existence of bacteria (other than those essential to the metabolisms of bodies and plants) as an issue of managing their populations to acceptable levels that do not endanger the health of people or plants. The major research unknowns at this point are the problems caused by biofouling (bacteria colonization of pipes, filters, and other critical points) and denitrifying the nutrient solution (causing inefficiency by creating a nitrogen loop that bypasses the crops), especially when CELSS are up and running for extended periods of time in nearly-closed modes (still in the future).

Thus, the inhabitants of an initial CELSS would be farmers and sanitation engineers, and only in the more distant future would become also dairy persons, aquaculturalists, and pig farmers. Yet even this simplified version of a complete agro-ecosystem, with crops and people as major functional living components, offers a challenging first milestone because, simply, it has never been done before in the highly miniaturized unit necessary to compete with the alternative scenario of re-supply of the various masses from Earth. For example, estimates (depending on the assumptions and degree of material closure desired) have computed that the potential payoff times for the initially higher launch mass of a CELSS system to compensate for the continually accumulating sum of re-supplied mass could be on the order of a decade or even much less (Olson et al., 1985). And the issues raised earlier by MacElroy are already present in a simplified CELSS, namely, issues of stability and maintainability of a complex synthesis of physical-chemical subsystems and life.

### **3. Miniaturized CELSS**

Simplifying is one way to reduce the total requirements of mass, volume, and power. But once certain essential components are decided upon, then the goal becomes one of miniaturizing. With the sizes and needs of human bodies there is not much to be done. Miniaturized equipment, however, is another issue and one for which NASA is deservedly famous.

A current example of miniaturization is the CELSS Test Facility (CTF) planned for the space station. The work, centered thus far at Ames Research Center, has designed an experimental crop growth facility to accommodate as much as 0.75 m<sup>2</sup> of growth area in slightly more than 2 m<sup>3</sup> of space station rack volume. This volume must include feed gas and nutrient reservoirs, pressure buffers, water vapor condensers, high-intensity lights, air circulation ducts, heat exchangers, controllers, and crew access to take

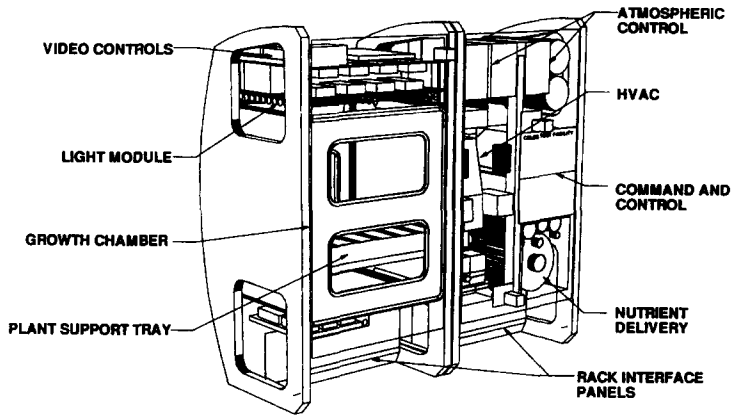

Fig. 2. Isometric view of the proposed CELSS Test Facility for the space station.

samples without breaking the essentially closed boundary during the experiment. Fig. 2 shows one design for the CTF.

Other than the obvious demand for miniaturizing all the support envelope of physical-chemical equipment around the humans and the crops, the biggest area for active research concerns the crops. To what levels can the planting volume or area per person be reduced? The CELSS program has university researchers active in selecting and in some cases breeding crops specialized for the limited space of a CELSS. Selecting high-yielding dwarf wheat, for example, has been ongoing at Utah State University. In the thick and even, 30 cm-high stands of brassica with their drooping seed pods – an oil crop under scrutiny at Purdue University – it is easy to visualize how a CELSS farm stand would look.

It is also important, when possible, to focus on crops that are daylength insensitive and can thus handle 24 h of light. This maximizes the time that photons can be pumped into chemical compounds and thereby reduces the total planted area. Another direction the CELSS program has taken is in the exclusive use of hydroponics. First of all, plant root mass is reduced in hydroponics by a factor of 50% or more compared to growth in soil or soil-type media. Secondly, hydroponics directly reduces the system mass by eliminating the soil matrix. At Kennedy Space Center, for example, hydroponic wheat, soybeans, lettuce, and potatoes grow on a thin film of flowing nutrient solution. Potatoes can put out full tubers in hydroponics (see Wheeler et al., 1990).

The question driving research into crop optimization is – How small an area could actually feed a person? The answer to this question has been provided in most detail by Bruce Bugbee and Frank Salisbury at Utah State University. It is dependent upon the light intensity (specifically, the photosynthetic photon flux, PPF) and whether a crop can respond to high PPF levels without saturating its per leaf area photosynthetic capacities. Wheat is particularly good in this regard because its vertical leaves spread the effective light over a wider leaf area; the plants can be grown successfully at extraordinarily high densities (Bugbee and Salisbury, 1988).

The answer to the area question also depends on the crucial issue of total photosyn-

thetic efficiency. This has been divided into a series of components that can be analyzed separately. These are: PPF absorption, canopy quantum yield, carbon use efficiency, and harvest index. (These components and much of the ensuing discussion is based on Bugbee and Monje, 1992; and Bugbee and Salisbury, 1988). Each component can be analyzed in terms of its own potentially achievable maximum (in units of energy). For example, the potentially achievable maximum absorption of PPF is close to 100% (about 98%, given the leaf albedo). And this is already achieved in the dense growth of the CELSS experiments following the rapid closure of the canopy (at about one-quarter of the 60–80 day life cycle for the wheat stands, somewhat longer for soy and potatoes).

For quantum yield the theoretical maximum is 1 carbon atom fixed per 8 photons of photosynthetically active radiation. For reasons still disputed, only about 1 carbon atom per 12 photons is the observed maximum during short-term leaf measurements. So in a CELSS canopy this is the approximate goal by which to evaluate experimental progress.

The next component in the series, the carbon use efficiency, measures the efficacy by which carbon fixed in simple primary sugars gets converted into the myriad of other compounds in the crop. Computing the potentially achievable maximum conversion of this so-called biosynthesis of structural carbohydrates, proteins, lipids, and others is complicated and still contains uncertainties. The most detailed theory has been set forth by Penning de Vries et al. (1974). The maximum carbon use efficiency depends upon the relative proportions of compounds synthesized in the crop, but a good working number is about 75–80%.

Putting numbers like these together, for example, a 95% PPF absorption, a quantum yield of 1 carbon atom per 13 photons of PPF, and a carbon use efficiency of 75%, Bugbee and Salisbury (1988) computed an overall upper efficiency of biomass production of 13%. This is, of course, prior to the final component of the series, the harvest index. In reality this last can vary from about 45% for wheat to 80% for potatoes and perhaps a little higher for lettuce. Of course one wants a crop with as little "waste" biomass as possible.

Let us imagine for a moment a genetic manipulation that allowed us to eat the entire crop biomass (a harvest index of 100%), which was produced with the upper limit of the photon-to-biomass conversion of 13% and driven by a level of PPF equal to  $1400 \mu\text{mol m}^{-2} \text{ s}^{-1}$  (currently used at Utah State University). One then could supply a person's caloric needs of  $2500 \text{ kcal d}^{-1}$  with about  $3 \text{ m}^2$  of growth area. [As in Bugbee and Salisbury (1988), this assumes that PPF contains  $217 \text{ kJ mol}^{-1}$ .] This "ultimate CELSS" is at least instructive. The reality, of course, is different. (Not to mention that a diet is more than calories, but nutritional composition is beyond the scope of this paper.)

How well are we doing? A clearcut answer is difficult because many experiments in the CELSS program are performed to answer specific questions about crop growth, for example, to test the effects of  $\text{CO}_2$  levels or to monitor nutrient uptake or air quality in a "closed" operating mode, and not to always push the system to its limit, especially in terms of lighting. However, in standard experimental runs at Utah State University, wheat converts atmospheric carbon into biomass at a rate of nearly  $70 \mu\text{mol CO}_2 \text{ m}^{-2} \text{ s}^{-1}$  during the light, for a net crop growth rate of  $110 \text{ g carbon m}^{-2} \text{ d}^{-1}$  during the plateau of peak efficiency at about halfway into the life cycle. Assuming  $18 \text{ kJ g}^{-1}$  in the average biomass (seed is slightly higher, leaves lower), and computing from 20 h of

light  $\text{d}^{-1}$  at  $1400 \mu\text{mol m}^{-2} \text{s}^{-1}$ , this peak photosynthesis chugs along at about 9% conversion efficiency, not too far off from the 13% "ultimate".

Additional losses seem inevitable. Early in the life cycle the unclosed canopy results in low total absorption. Later in a crop's life the quantum yield gradually declines due to leaf senescence. Also, a large loss in wheat occurs because only about 45% of the final total biomass is edible seed. Overall, the life cycle efficiency is still about double that found in record field yields.

#### 4. Mathematical modeling for optimizing crop growth

Aid for pushing the crop production still closer toward the potentially achievable maximum over the life cycle will probably come from collaborations between mathematical modelers and experimentalists. Because even at its simplest, CELSS will be complex, all the powers of systems and control engineering must be brought to bear on the design and operation. Models have indicated that the nonlinear dynamics coupled with the masses flowing in a closed system lead to some non-intuitive behaviors (Babcock et al., 1985). The coupling of the inherently unpredictable (to some degree) and complex behavior of crops (being life) with the simpler and more numerically rigorous physical and chemical systems of process engineering presents some challenging issues in control theory (Blackwell, 1990). There is a potential for fuzzy logic to help (Ken Tsai, NASA Ames Research Center, pers. comm., 1993).

One generic problem for the CELSS crop experiments is that the control engineers would like to know the behavior of the crops across a vast range of parameters. Typically it is desired to know the effects of variations in temperature, light,  $\text{CO}_2$ , humidity, nutrient concentrations, air velocity, and planting density, to name some of the major parameters. Experiments are time consuming, and therefore expensive, and must be planned judiciously to divulge the maximum information. Mathematical modeling has been playing a role in designing the optimal matrices of test variables (Miller et al., 1992).

One area under study is the time dependence and major features of the series of efficiencies in the crop's growth and development described in the preceding section, a series some call the energy cascade. Models can effectively describe the overall photosynthetic  $\text{CO}_2$  uptake during the period of light and its release during dark respiration with five basic trends (Volk et al., 1995). These are: a linear increase in PPF absorption to canopy closure, and thereafter constant; a constant canopy quantum yield until the onset of senescence and then a linear decrease to the end of the life cycle; and, finally, a constant carbon use efficiency over the life cycle. This approach to modeling the crop growth helps focus questions about where and how to aim potential improvements, because as quantifiable components, the trends of the energy cascade become individual areas for further research.

One potential area where mathematical modeling may be able to take a substantial role is in guiding experiments in the area of improving the harvest index. This component of the energy cascade is often the weakest link in the chain and not well

understood theoretically. It might be improved by the so-called phasic control of crop growth and development.

Phasic control entails providing the crop with different environmental conditions at different phases (or stages) of its life cycle. For example, warm conditions generally shorten the lengths of stages; cool conditions lengthen them (Ritchie, 1991). Both strategies might be employed during the life cycle at different times. Wheat could perhaps be quickly progressed by relatively high temperatures to the initiation of the grain primordia; and then this developmental rate could be slowed with cooler temperatures until establishment of the final terminal spiklet, which effectively locks the future number of flowers and hence potential grains.

It will be nearly impossible to perform the relevant number of experiments to study the complete response space of phasic control. There already exist, fortunately, elaborate field crop models whose most sophisticated features reside in their ability to predict the stage shifts in development from weather conditions. These models include Ceres for wheat (Ritchie, 1991) and Soygrow for soy (Jones et al., 1991). The research potential exists to employ these field models to help guide the CELSS crop experiments into a phasic control strategy that optimizes the overall conversion of energy into edible biomass and furthers the goal of miniaturizing the total system. The field models need to be modified, however, by including, for instance, the crop response to CO<sub>2</sub> levels (Tubiello et al., 1995), since the CELSS crop experiments use enhanced CO<sub>2</sub>.

## 5. Conclusions

This paper was written to convey a sense of the activities of the CELSS program in the context of mesocosms. The focus has been two qualities that make CELSS unique in the overall field of mesocosm research: its highly simplified agro-ecology, and its overriding thrust toward miniaturization. The current research is headed toward systems in space perhaps a decade or two from now, and it will take that long for reliable systems to be ready when the space program is ready for them. The research and testing described and many other issues not discussed here constitute an ongoing, active, and exciting program. A portion of the efforts at the NASA centers, such as Kennedy Space Center and Ames Research Center, have already been hinted at. In addition, a human occupied test bed is being built at Johnson Space Center. Since many readers may be hearing about the CELSS program for the first time, and since this paper was not able to fully present the many aspects of the program, for more information please contact this author or Robert MacElroy at Ames, Donald Henninger at Johnson, Bill Knott at Kennedy, and Mel Averner at NASA Headquarters.

## Acknowledgements

The views expressed in this paper are solely those of the author and do not necessarily represent those of the advanced life support program or any particular other individuals in the program. Work was supported through NASA Grants NCC2-608 and NAGW-4125 to New York University.

## References

- Babcock, P.S., D.M. Auslander and R.C. Spear, 1985. CELSS transportation analysis. In: R.D. MacElroy, D.T. Smernoff and H.P. Klein (Eds.), *Controlled Ecological Life Support System*. NASA Conference Publication 2378, pp. 47–54.
- Blackwell, A.L., 1990. A perspective on CELSS control issues. In: R.D. MacElroy (Ed.), *Controlled Ecological Life Support Systems: CELSS '89 Workshop*. NASA Technical Memorandum 102277, pp. 327–353.
- Bugbee, B. and F.B. Salisbury, 1988. Exploring the limits of crop productivity. *Plant Physiol.*, 88: 869–878.
- Bugbee, B. and F.B. Salisbury, 1989. Controlled environment crop production: hydroponic vs. lunar regolith. In: D.W. Ming and D.L. Henninger (Eds.), *Lunar Base Agriculture*. American Society of Agronomy, Madison, WI, pp. 107–129.
- Bugbee, B. and O. Monje, 1992. The limits of crop productivity. *BioScience*, 42: 494–502.
- Gitelson, J.I. and Y.N. Okladnikov, 1994. Man as a component of a closed ecological life support system. *Life Supp. Biosph. Sci.*, 1: 73–81.
- Gitelson, J.I., I.A. Terskov, B.G. Kovrov, G.M. Lisovskii, Yu.N. Okladnikov, F.Ya. Sidko, I.N. Trubachev, M.P. Shilenko, S.S. Alekseev, I.M. Pankova and L.S. Tirranen, 1989. Long-term experiments on man's stay in biological life-support system. *Adv. Space Res.*, 9: 65–71.
- Jones, J.W., K.J. Boote, S.S. Jagtap and J.W. Mishoe, 1991. Soybean development. In: J. Hanks and J.T. Ritchie (Eds.), *Modeling Plant and Soil Systems*. American Society of Agronomy, Madison, WI, pp. 71–90.
- MacElroy, R.D., J. Tremor, D.T. Smernoff, W. Knott and R.P. Prince, 1987. A review of recent activities in the NASA CELSS program. *Adv. Space Res.*, 7: 53–57.
- Miller, A.M., M. Edeen and R.J. Sirko, 1992. Plant growth modeling at the JSC variable pressure growth chamber: an application of experimental design. SAE Technical Paper #921356. Society of Automotive Engineers, Warrendale, PA.
- Ming, D.W. and D.L. Henninger (Eds.), 1989. *Lunar Base Agriculture*. American Society of Agronomy, Madison, WI, 255 pp.
- Nelson, M., T.L. Burgess, A. Ailing, N. Alvarez-Romo, W.F. Dempster, R.L. Walford and J.P. Allen, 1993. Using a closed ecological system to study the Earth's biosphere. *BioScience*, 43: 225–236.
- Olson, R.L., E.A. Gustan and T.J. Vinopal, 1985. CELSS transportation analysis. In: R.D. MacElroy, D.T. Smernoff and H.P. Klein (Eds.), *Controlled Ecological Life Support System*. NASA Conference Publication 2378, pp. 55–64.
- Penning de Vries, F.W.T., A.H.M. Brunsting and H.H. van Laar, 1974. Products, requirements and efficiency of biosynthesis: A quantitative approach. *J. Theoret. Biol.*, 45: 339–377.
- Ritchie, J.T., 1991. Wheat phasic development. In: J. Hanks and J.T. Ritchie (Eds.), *Modeling Plant and Soil Systems*. American Society of Agronomy, Madison, WI, pp. 31–54.
- Tubiello, F.N., C. Rozensweig and T. Volk, 1995. A modified Ceres-wheat model to simulate the interactions of CO<sub>2</sub>, temperature, and management techniques. *Agricult. Syst.*, 49: 135–152.
- Volk, T., 1993. Comments on "Bioprocessing in space". *Enzyme Microb. Technol.*, 15: 899–900.
- Volk, T. and J.D. Rummel, 1987. Mass balances for a biological life support system simulation model. *Adv. Space Res.*, 7: 141–148.
- Volk, T. and J.D. Rummel, 1989. The case for cellulose production on Mars. In: C. Stoker (Ed.), *The Case For Mars III; Strategies for Exploration – Technical*, Vol. 75. American Astronautical Society Science and Technology Series, AAS, San Diego, CA, pp. 87–94.
- Volk, T., B. Bugbee and R.M. Wheeler, 1995. An approach to crop modeling with the energy cascade. *Life Supp. Biosph. Sci.*, 1: 119–127.
- Westgate, P., K. Kohlman, R. Hendrickson and M.R. Ladisch, 1992. Bioprocessing in space. *Enzyme Microb. Technol.*, 14: 76–79.
- Wheeler, R.M., C.L. Mackowiak, J.C. Sagar, W.M. Knott and C.R. Hinkle, 1990. Potato growth and yield using nutrient film technique (NFT). *Am. Potato J.*, 67: 177–187.